

# INSTRUCTION AND REPAIR MANUAL

ENGLISH: PAGES 2-12

NOTE! To the installer: Please make sure you provide this manual to the owner of the equipment or to the responsible party who maintains the system.





**CALIFORNIA PROPOSITION 65 WARNING:**

**⚠ WARNING** This product and related accessories contain chemicals known to the State of California to cause cancer, birth defects or other reproductive harm.

At initial installation and before starting a unit that has been shut down for repairs or for any extended length of time, run enough 10/20 weight motor oil

MODEL 431B

reused. All optional packing and gaskets should be replaced with new ones at reassembly simply as a matter of economy; they are much less expensive to replace routinely than to replace as the need occurs. In general it is economical to return to the manufacturer for repair only the motor and motor controller

4. Loosen and remove capscrews (6) securing upper casing (8) to remainder of pump assembly.

NOTE

Disassembly procedure from this point covers pumps having standard mechanical seals. If



MODEL 431 B

TWO STAGE PUMP SHAFTS  
LOCATION OF SHAFT SLEEVE ON SHAFT  
R.H. ROTATION

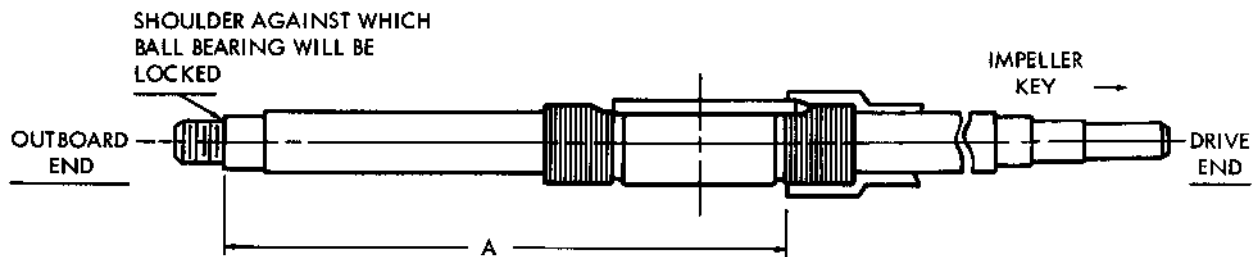

POWER SERIES	PUMP SIZE	A
2	1-1/2 x 3 x 9 2 x 4 x 9	12-49/64
3A	1-1/2 x 3 x 11 2 x 4 x 11	14-59/64

Figure 2

TWO STAGE PUMP SHAFTS  
LOCATION OF SHAFT SLEEVE ON SHAFT  
L.H. ROTATION

SHOULDER AGAINST WHICH  
BALL BEARING WILL BE

1

IMPELLER

MODEL 431B

2. On a right hand unit, thread inboard sleeve (65) onto shaft (71) distance "A" (refer to Figure 2). On a left hand unit, thread outboard sleeve (57) onto shaft distance "A" (refer to Figure 3). When the sleeve is in place its keyways should align with keyways on shaft.

4. Install mechanical seals and optional packing according to the following specific instructions:

Mechanical Seal, single

Insert key (68) into keyways of shaft and sleeve. Tap key firmly in place.

3. On right hand unit proceed to assemble the

I. Slide one seal lock collar (54) with setscrews (55), with spring shoulder facing away from impeller, onto each end of the shaft. Position on scribe made during disassembly and lock in place.

II. Put a coating of mechanical seal lubricant on if

MODEL 431B



8. Protector (29) can be placed in cartridge cap.

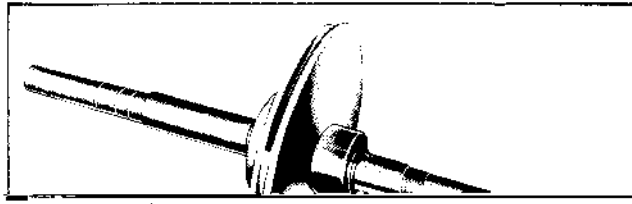





MODEL 431B

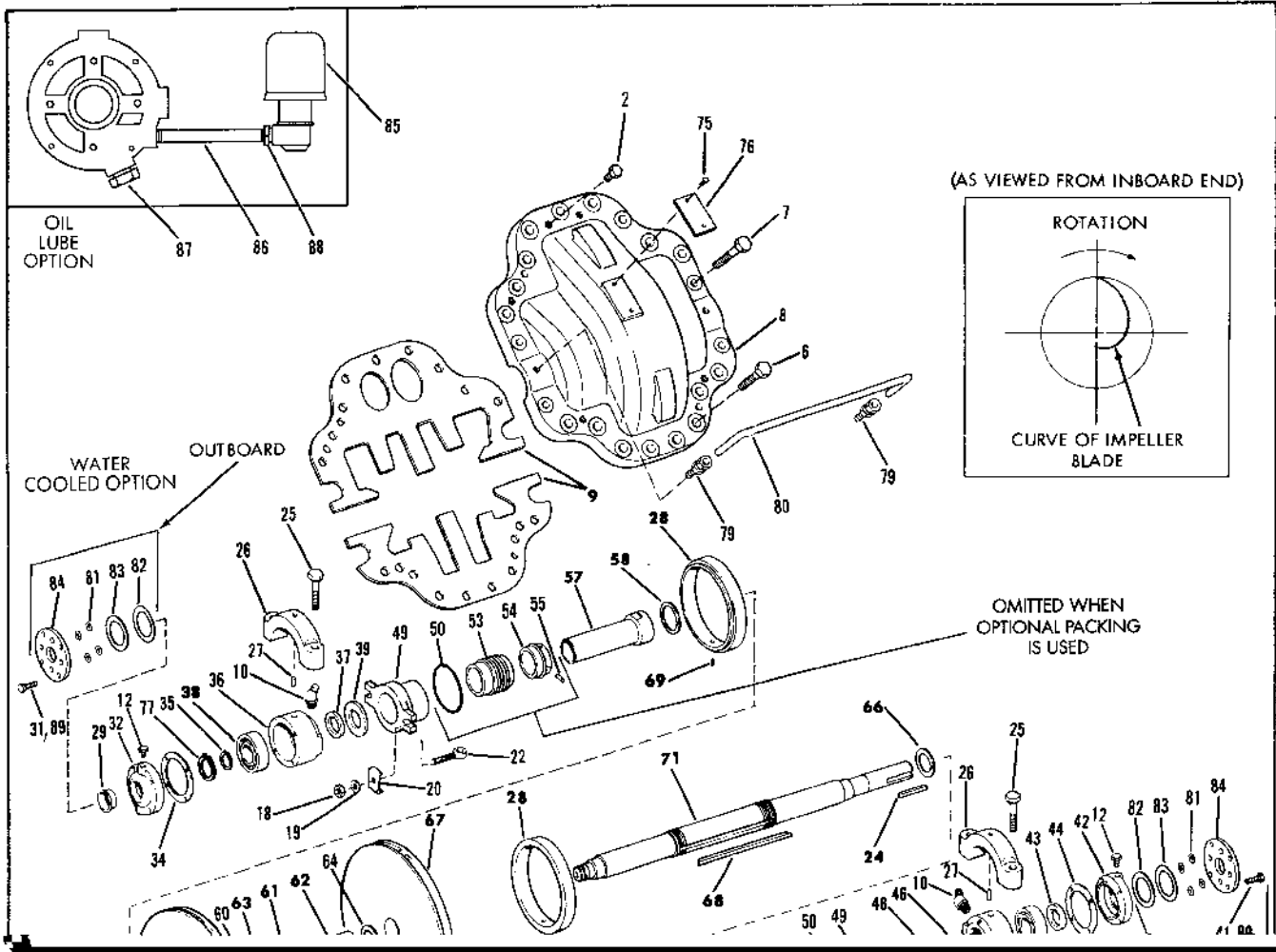



## **WARRANTY**

Seller warrants equipment (and its component parts) of its own manufacture against defects in materials and workmanship under normal use and service for one (1) year from the date of installation or start-up, or for eighteen (18) months after the date of shipment, whichever occurs first. Seller does not warrant accessories or components that are not manufactured by Seller; however, to the extent possible, Seller agrees to assign to Buyer its rights under the original manufacturer's warranty, without recourse to Seller. Buyer must give Seller notice in writing of any alleged defect covered by this warranty (together with